

Centering Clamping Mandrels • cylindrical

23340.0516



Product Description

The centering clamping mandrels, cylindrical are ideal for use in fixture construction. They enable workpieces to be clamped with a hole on their inside diameter and therefore without interfering clamping edges. The centering clamping mandrels can be mounted on grid and fixture plates, for example, by pressing them into bores or screwing them into threads.

They enable exact positioning, offer precise repeat accuracy and achieve high holding forces when clamping parts with holes. The centering clamping mandrels offer the possibility of fixing complex workpieces without external clamping elements to enable these components to be machined on 5 sides.

The centering clamping mandrels, cylindrical have the following characteristics:

- Clamping stroke max. 0.7 mm
- Two versions - for press-in or screw-in
- Made of stainless steel or free-cutting steel
- Clamping body can be machined very easily (for adaptation to bore diameter)

Material

Body

- Free cutting steel, blackened

Clamping screw

- Steel

Assembly

The centering clamping mandrel can be adjusted to the respective diameter by turning or milling.

Picture 1 - Mounting in bore hole or socket.

Thread for clamping screw required.

Picture 2 – Mounting in thread.

Remove the clamping screw from the body for the assembly. Screw-in centering clamping element and tighten using the wrench size (WS₂).

Operation

It is operated using the conical clamping screw (WS₁). This expands the body by up to 0.7 mm.

Drawing

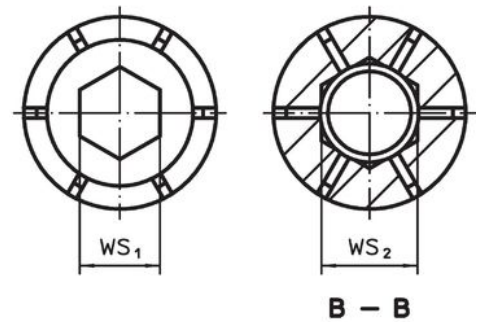
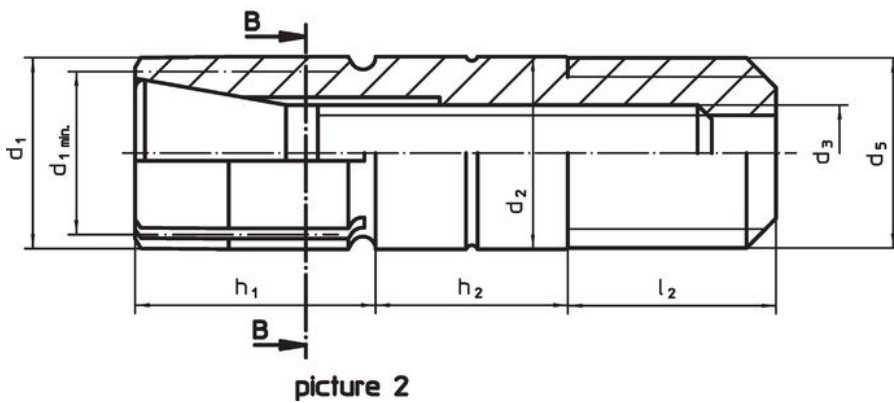
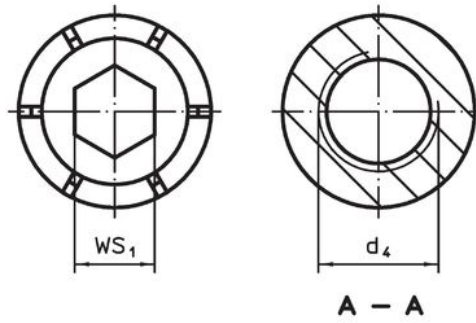
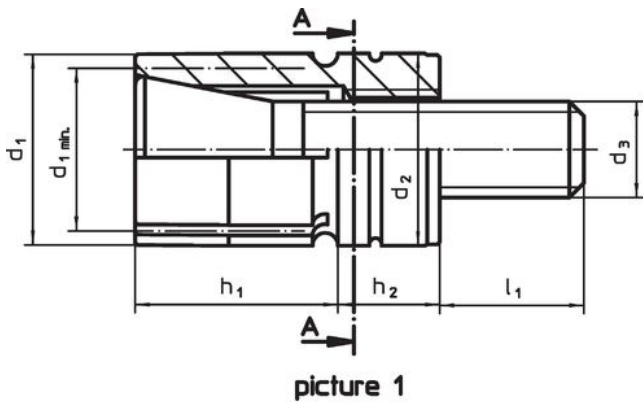

Order information

d ₁	d ₁ min.	d ₂ -0.025	Dimensions					WS WS ₁	Number of segments	Clamping force max. [kN]	Tightening torque max. [Nm]	Location hole H7 [mm]	Art. No.	
			d ₃	d ₄	h ₁	h ₂	l ₁							[mm]
press-fit – picture 1, Free cutting steel														
16	12	16	M8	M10	12.7	6.35	13	6	6	11.1	34	16	29	23340.0516

Application example

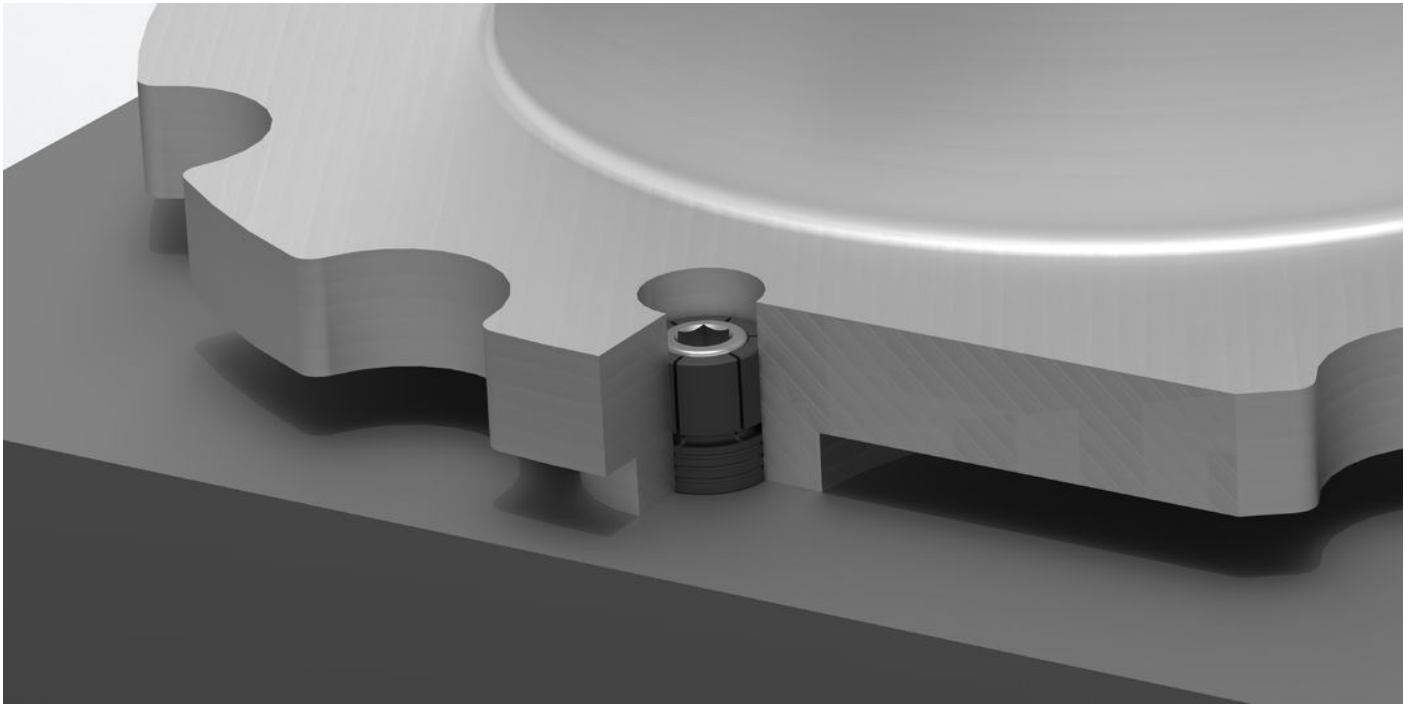

Compliance

RoHS compliant

Compliant according to Directive 2011/65/EU and Directive 2015/863.

Does not contain SVHC substances

No SVHC substances with more than 0.1% w/w contained - SVHC list [REACH] as of 27.06.2024.

Does not contain Proposition 65 substances

No Proposition 65 substances included.
<https://www.P65Warnings.ca.gov/>

Free from Conflict Minerals

This product does not contain any substances designated as "conflict minerals" such as tantalum, tin, gold or tungsten from the Democratic Republic of Congo or adjacent countries.